

Secure Doc Office III

for fire protection of paper documents

Are you looking for a cabinet that will protect your valuable documents from fire? Well, Secure Doc Office III is just what you are looking for.



The Secure Doc Office III range has a fire protection classification of 120 Paper, which means that documents stored in the cabinets will be protected from fire for two hours. Statistics show that more than 80% of all companies that have been exposed to a fire have become bankrupt within three years. The Secure Doc Office III offers high-level fire protection for documents and ensures the continuation of your business.

Models

The Secure Doc Office III is available in five models and is specially designed for use in office environments. With its large capacity and removable shelves you will always be able to find the optimum storage configuration for binders and documents.

Locking

The cabinets are equipped with an electronic lock as standard. The lock has two programmable six-digit user codes, an anti-spy function and a self-testing system.

Certification

The Secure Doc Office III range is tested in accordance with NT Fire 017 – 120 Paper, which means that your paper documents are protected from fire for two hours. Thanks to its insulated walls, the internal temperature of the cabinet will not rise above 177°C.

Additional features

To maximise storage, all cabinets are supplied with a lockable drawer and adjustable shelves as standard. Furthermore, an optional fire insert is available for storing data media such as CDs, DVDs and back-up tapes.

Design

The Secure Doc Office III range will complement any user environment and is supplied in a modern two-tone finish.

Secure Doc Office III

Models

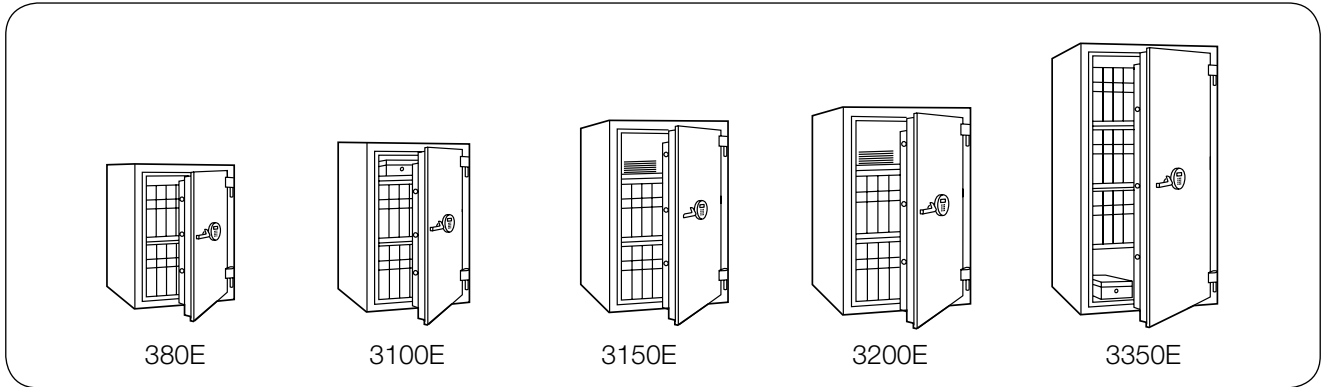

SLGB.7003.R1

Product data

120 Paper

Model	Article No.	External dimensions (mm)			Internal dimensions (mm)			Volume (litres)	Weight (kg)	Shelf (qty)	Drawer (qty)
		Height	Width	Depth	Height	Width	Depth				
SDO-380E	SL03710	796	580	507	643	427	346	95	163	1	1
SDO-3100E	SL03711	993	585	507	834	462	346	133	218	2	1
SDO-3150E	SL03712	1178	646	632	1019	487	471	234	293	2	1
SDO-3200E	SL03713	1288	741	632	1129	582	471	309	333	2	1
SDO-3350E	SL03714	1598	741	632	1439	582	471	394	403	3	1

SecureLine policy is one of constant improvement. The specification above may therefore be altered without prior notification.

www.Secure-Line.net

Authorised dealer:

